

ski-doo

ALPINE VALMONT

'73 Owner's Manual

*Trademark Bombardier Limited

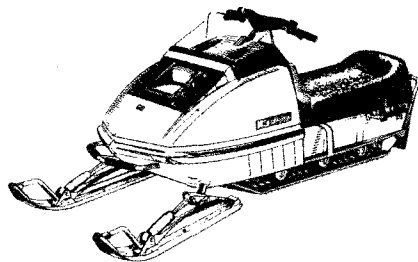
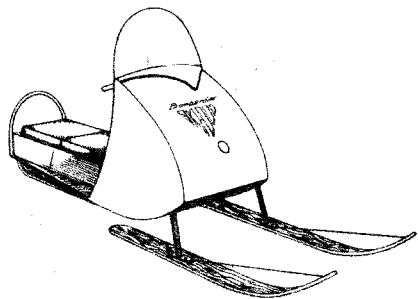

THE COMPANY THAT CHANGED WINTER HAS CHANGED

In 1957 and 1958, tests began on what is considered the forerunner of the Ski-Doo*. We experimented with many different frames and engines—in search of a light machine for one or two passengers. By the fall of '58, the first prototype was ready. Initial tests made it obvious the machine could hold its own in the recreation market. Production began one year later and 225 machines were sold at about \$1,000 each.

Like its predecessors the '73 Ski-Doo snowmobile is a combination of lightness, economy, strength and dependability. And yet, with all this, it has one other additional feature . . . personality.

Each model in each series has a complexity of characteristics that distinguishes itself as part of a bold breed . . . **the Ski-Doo snowmobiles.**

At Bombardier, we fully realize that the purchase of a snowmobile is a very important decision. For this reason, we have ensured that each Ski-Doo snowmobile is backed up by an international Ski-Doo Distributor and Dealer Network whose factory trained personnel are equipped to give you prompt and efficient service wherever you are in Snow Country.

Furthermore, each dealer is prepared to serve you with information, parts and accessories. Feel free to contact him.

At this time we would like to thank you for your patronage and welcome you to Winter. Enjoy yourself but remember: Safety depends on you, the driver, the condition of your vehicle and nature of the terrain.

All of the information, illustrations and component/system descriptions contained in this manual are correct at the time of publication. However, Bombardier Limited reserves the right to make changes in design and specifications, and/or to make additions to or improvements in its products without imposing any obligations upon itself to install them on its products previously manufactured.

This manual has been published by the Technical Information Centre, Bombardier Limited, 8600 Decarie Blvd., Montreal 307, Quebec, Canada.

*Trademark Bombardier Limited



INDEX

*The following are trade marks of Bombardier Limited.

Ski-Doo	Valmont	Skandic
Ski-Boose	T'NT	Carry-Boose
Nordic	Elan	Bombardier
Alpine	Blizzard	

PATENTS and DESIGNS

This vehicle is covered by one or more of the following patents and design registrations.

Canadian Patents: 605,317 - 710,592 -
724,395 - 853,505

United States Patents: 2,899,242 - 3,066,546 -
3,536,153

Canadian Designs: DI/217 F/28172 -DI/249
F/31317 and '316 -D32,479 - D32,535 -
D32,655 to '657 - D32,661 to '669 -
33,982 -33,933 - 34,006 and '007.

United States Design Patents:

Des. 221,332 to '334 -
Des. 221,637 and '638 -
Des. 222,244 to '247.

Others: Swedish Design No. 6038 -
Swiss Design No. 104,756 -
Norwegian Design No. 51,444.

WHAT YOU SHOULD KNOW BEFORE FIRST RIDE	2
SERVICE AREAS	3
CONTROLS / INSTRUMENTS	4, 5
FUEL MIXING	6, 7
BREAK-IN PERIOD	7
PRE-START CHECK	8
STARTING PROCEDURE	9
LUBRICATION	10, 11, 12
MAINTENANCE	13, 14, 15, 16, 17
EMERGENCY GUIDE	17
TROUBLE SHOOTING	18, 19
OFF-SEASON STORAGE	20, 21
SPECIFICATIONS	22, 23
WARRANTY	24

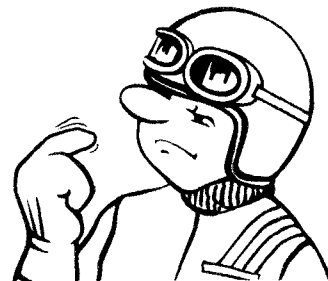

WHAT YOU SHOULD KNOW . . . before first ride.

To many of us, Winter is a revealing experience. Weather, atmospheric conditions, snow surfaces, individual driving habits and vehicle usage have considerable affects. We ask that you familiarize yourself with them . . . **read** the owner's manual; it has been prepared to acquaint you with the operation of your vehicle, its safety aspects and systems as well as preventative maintenance procedures that must be periodically upheld . . . all aimed toward a more enjoyable Winter season.

Observe the following precautions:

- Throttle mechanism should be checked for free movement **before** starting engine.
- Engine should be running **only when** pulley guard is secured in place.
- **Never** run engine without drive belt installed. Running an unloaded engine

can prove to be dangerous.

- **Never** run the engine at high R.P.M. when the track of the vehicle is raised off the ground.
- It can be dangerous to run engine with the **cab open**.
- Prolonged sitting while riding over rough terrain may cause kidney and/or spinal discomfort, specially for the driver or passenger having an existing back weakness.
- Gasoline is flammable and explosive under certain conditions. Always perform procedures in a well ventilated area. Do not smoke or allow open flames or sparks in the vicinity. If gasoline fumes are noticed while driving, the cause should be determined and corrected without delay.
- **Under no circumstances** should you wear loose clothing or scarves that

could become entangled with moving parts of your snowmobile.

- Your snowmobile **is not** designed to be operated on public streets, roads or highways. In most States and Provinces, it is considered an **illegal** operation.
 - Hidden telephone guy wires or roadside ditches can cause serious **accidents**.
 - Your snowmobile **is not** designed to be driven or operated on black top, bare earth, or other abrasive surfaces. Abnormal and excessive wear of critical parts is inevitable.
 - **Always** wear an approved snowmobile safety helmet. Be informed on local laws legislating the sport.
 - Maintain your vehicle in top mechanical condition at all times.
- Please read and understand all other warnings contained elsewhere in this manual.**

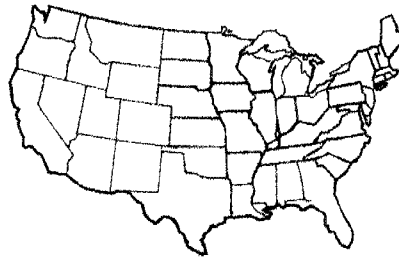

We recommend you contact your local Authorized Ski-Doo dealer when your Ski-Doo snowmobile requires service. However, for further inquiries, you may contact your Regional Distributor listed below.

SERVICE AREAS

CANADIAN DISTRIBUTORS

Name of Distributors	Coverage Area
ALPINE DISTRIBUTORS 3206 - 28th Ave., Vernon, B.C.	British Columbia
ATLANTIC SKI-DOO LTD. P.O. Box 670, Shediac, N.B.	Prince Edward Island Magdalen Island Nova Scotia New Brunswick
BOMBARDIER ONTARIO LTD. 28 Currie St., Barrie, Ont.	Ontario
BOMBARDIER QUE. LTD. 1350 Nobel St. Boucherville, Que.	Quebec
BROOKS EQUIPMENT LTD. Box 985, Winnipeg 21, Man.	Manitoba Saskatchewan
HUDSON'S BAY CO. 121 Richmond W. Toronto, Ont.	North-West Territories
J. W. RANDALL LTD. P.O. Box 757, Corner Brook, Newfoundland	Newfoundland
TRACT EQUIPMENT LTD. 14325 - 114th Ave., Edmonton, Alta.	Yukon Alberta

AMERICAN DISTRIBUTORS

Name of Distributors	Coverage Area
BOMBARDIER EAST INC. Railroad St., Lee, Massachusetts 01238	Massachusetts Connecticut Rhode Island
BOMBARDIER WEST INC. 609 West Broadway, Idaho Falls, Idaho 83401	California Nevada Montana Idaho Wyoming Utah New Mexico Arizona Kansas Nebraska Washington Oregon Colorado
CRAIG TAYLOR EQUIPMENT CO. P.O. Box 3338, Anchorage, Alaska 99501	Alaska
ELLIOTT & HUTCHINS INC. East Main Street Road, Malone, New York 12953	New York Pennsylvania New Jersey Maryland Delaware District of Columbia Virginia

HALVORSON INCORPORATED 325 South Lake Avenue, Duluth 2, Minn. 55802	North Dakota South Dakota Minnesota Wisconsin Iowa Illinois Missouri Upper Michigan
HEATH INTERNATIONAL INC. 33737 - 32 Mile Road, Richmond, Mich. 48062	Lower Michigan Indiana Ohio Tennessee Kentucky W. Virginia
TIMBERLAND MACHINES INC 10 Main St. North, Lancaster, New Hampshire 03584	Maine New Hampshire Vermont

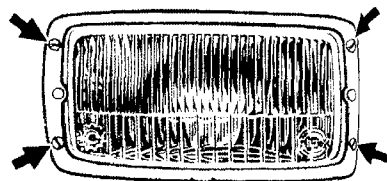
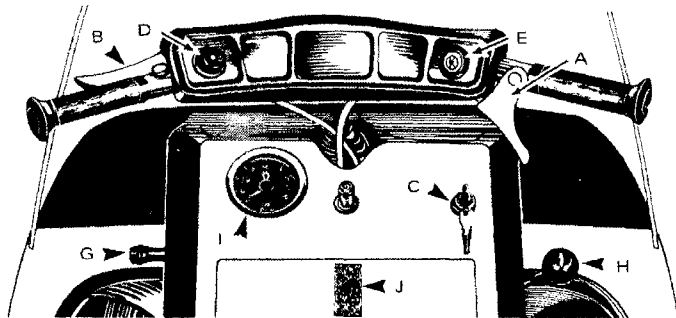

CONTROLS/INSTRUMENTS

Steering

Rotation of the handlebar causes a push pull action on the steering linkage and forces the ski to turn in the required direction. Incorporated in the crash padded handlebar are the dimmer switch, kill button, brake and throttle levers.

Throttle Lever (A)

Located on right side of handlebar. When depressed, the lever controls the engine speed and the engagement of the transmission. When lever is released engine speed returns automatically to idle.

Brake Lever (B)

Located on left side of handlebar. When lever is depressed, the brake is applied. When released, it automatically returns to its original position. Braking effect is proportionate to the applied pressure on the lever.

Ignition / Light Switch (C)

(Manual Models only)

Key operated, 3 position switch (OFF/ON/LIGHTS). To start engine, first turn key clockwise to ON position. To stop engine, turn key counter-clockwise to OFF position. Turning key fully clockwise with engine running, illuminates both headlamp and taillight.

Ignition / Light Switch

(Electric Models only)

Key operated, 4 position switch, (OFF/LIGHTS/ON/START). To start engine, turn key fully clockwise to START position and hold. Return key to ON position **immediately** engine has started. To illuminate both headlamp and taillight turn key to LIGHTS position.

Headlamp Dimmer Switch (D)

The dimmer switch, located on left side of handlebar, allows correct selection of headlamp beam. To obtain Hi or Low beam simply depress switch.

Note: The angle of your headlamp beam has been pre-adjusted prior to delivery. Should you wish readjustment, remove headlamp chrome ring and turn upper or lower adjusting screws to obtain desired beam position.

Kill Button (E)

A push button switch located on right side of handlebar. For emergency stops, press button down into **lower** position. Before re-starting engine always depress button into released **upper** position.

The driver of this vehicle should familiarize himself with the function of this device by using it several times on first outing, thereby being mentally prepared

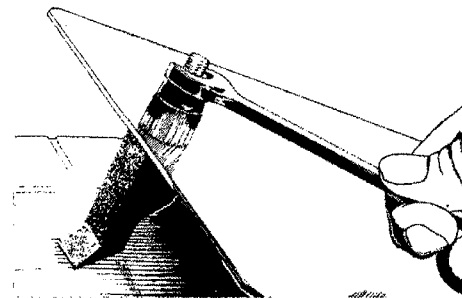
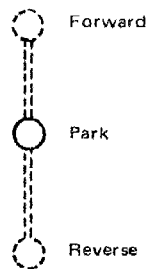
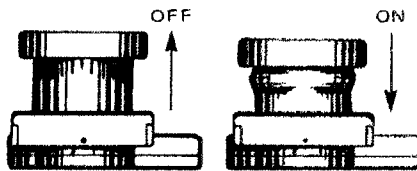

for emergency situations requiring its use. After such a situation, the source of malfunction should be determined and corrected before re-starting engine.

Manual Starter (F)

Auto-rewind type located at lower right side of console. To start engine, pull handle. (See Starting Procedure)

Choke (G)

A push-pull button. Pull button to engage choke, push to disengage. The choke should always be used for easier cold engine starts. After engine is warmed up however, it is not necessary to use choke when starting.

Gear Shift Lever (H)

A 3 position, (FORWARD/PARK/REVERSE) gear shift lever. Push **up** for forward, **center** for park and **down** for reverse.

Warning: Do not activate gear shift lever while snowmobile is in motion. Never run the engine at high R.P.M. when lever is in park position.

Tachometer (I)

The tachometer registers the impulses of the magneto. Direct reading dial indicates (in thousands), the number of revolutions per minute (R.P.M.) of the engine.

Access Door (J)

To gain access to the carburetor or spark plugs, lift pressure lock tab and pull open access door. To adjust locking device turn nut in required direction.

Fuel Level

Fuel level can easily be checked, at any time, by removing cab and glancing at translucent tank.

Seat Compartment

Remove backrest and tilt seat. Ideal location for spare plugs, belt, rope, etc.

Tips

Emergency materials should be wrapped in foam or similar material. This will prevent possible damage to breakable items when traveling over rough or bumpy terrain.

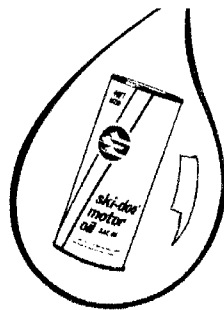
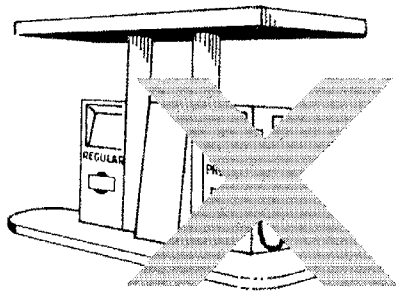

40:1

FUEL MIXING

With Ski-Doo snowmobiles, the **oil** must be added to the **gasoline** in pre-measured amounts then both oil and gasoline should be thoroughly mixed together **before** fueling the tank.

Which Gasoline to Use

The correct gasoline is **regular** gasoline, (not less than 88 octane), available from all service stations.

Caution: Never experiment with other than recommended fuels or fuel ratios. Never use no lead gasoline†, naphta, methanol or similar products.

Which Oil to Use

Use **concentrated** Ski-Doo* oil available from your Ski-Doo* dealer. This type of oil has specially formulated oil bases to meet the lubrication requirements of the Bombardier-Rotax engine.

†Tests are not conclusive enough therefore we do not recommend the use of no-lead gasolines

Caution: The carburetors of the 1973 Ski-Doo snowmobile have been calibrated for a mixture of gasoline and concentrated Ski-Doo oil.

Unless absolutely necessary, do not use regular snowmobile oil. If such oil is used, observe mixing instructions on the container. Never use outboard or straight mineral oils.

Fuel Mixing Ratio

The importance of using the correct fuel mixture cannot be overstressed. Prior experience has shown that an incorrect fuel ratio results in serious engine damage. The correct fuel/oil ratio is 40/1

5 gallons, recommended gasoline plus 1 pint Ski-Doo oil = correct fuel mixture.

Note: To facilitate fuel mixing, oil should be kept at room temperature.

Fuel Mixing Procedure

To mix the gasoline and oil always use a separate clean container. Never mix directly in your snowmobile tank. For best results, acquire two containers, either plastic or metal. Draw from one until empty then use the second one.

Warning: Gasoline is flammable and explosive under certain conditions. Always perform procedures in a well ventilated area. Do not smoke or allow open flames or sparks in the vicinity. If gasoline fumes are noticed while driving, the cause should be determined and corrected without delay. Never add fuel while engine is running.

- Pour the full amount of Ski-Doo oil required for the total mixture into the container.
- Add approximately half the amount of

*Trademark Bombardier Limited

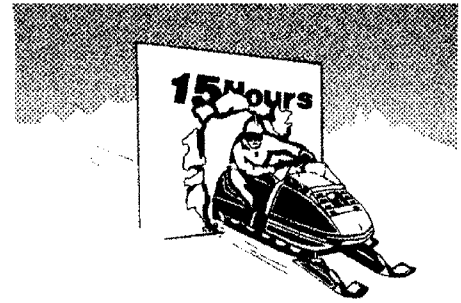
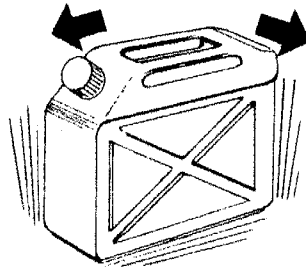
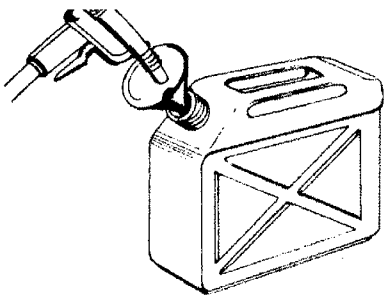

BREAK-IN

gasoline to be mixed.

- Shake the container thoroughly.
- Add the remainder of the gasoline.
- Once again thoroughly agitate the container.
- Using a funnel with a fine mesh screen to prevent the entry of water and foreign particles, transfer mixture from container into the snowmobile tank.

Note: When using pre-mixed fuel, always shake the container thoroughly as the oil has a tendency to settle.

Warning: Never 'top up' gas tank before placing vehicle in a warm area. At certain temperatures, gasoline will expand and overflow.

Fuel Consumption

A good idea is for you to rate the fuel consumption of your snowmobile at the first opportunity. Starting with a full fuel tank, mark the time of your departure then note time elapsed until tank is half-full. Repeat on different occasions to get a mean average of your snowmobiles' consumption and length of running time under varying conditions.

With Ski-Doo snowmobile engines, a break-in period is required **before** running the vehicle at full throttle. Manufacturer's recommendation for the Bombardier-Rotax engine is 10 to 15 operating hours. During this period, maximum throttle should not exceed $\frac{3}{4}$. However, brief full accelerations and speed variations contribute to a good break-in. Continued wide open throttle accelerations, prolonged 'cruising' speeds and lugging are detrimental during the break-in period.

Inspection

After the break-in period, we suggest that each Ski-Doo snowmobile has an inspection check. This inspection is at the discretion and expense of the vehicle owner.

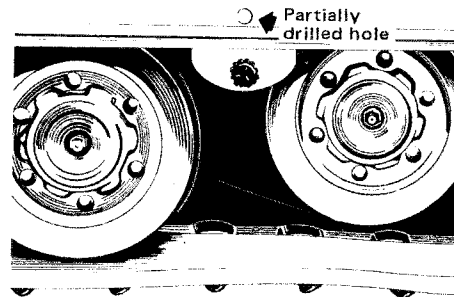
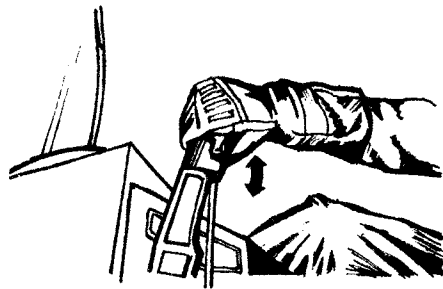
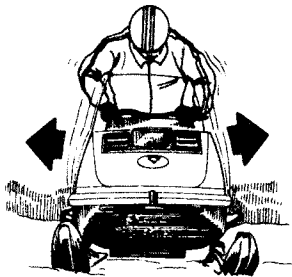

PRE-START CHECK

Fuel Tank Quantity

Check that there is sufficient fuel in the tank for your trip. A good habit to acquire is to refill the tank before starting out each day.

Since mixed fuel has a tendency to settle overnight, agitate the fuel in the tank by standing on the footboards and rocking the vehicle from side to side.

Steering Operation

Check operation of steering mechanism by moving the ski several times from side to side. If roughness or binding is felt, check for ice or snow that may be blocking the mechanism.

Throttle and Brake

Depress and release levers several times to check that they operate easily and smoothly. The throttle lever should return to the idle position when released. The brake lever should be fully applied when it has minimum clearance from the handlebar grip (see Maintenance, Brake). If the levers do not return swiftly, remove cables and/or housings and replace. Re-check lever operation.

Warning: Throttle mechanism should be checked for free movement before starting engine. Once all components are checked and functioning properly, you can start your Ski-Doo snowmobile.

Tips

By raising the outer attachment of the bogie wheel sets vehicle manoeuvrability in deep snow will increase. You will note that there are partially drilled holes, located approx. $1\frac{3}{8}$ " above the original cross shaft holes of the frame. To reposition bogie wheel sets, drill holes fully through using a $\frac{5}{16}$ " dia. drill. Remove capscrews securing bogie wheel cross shafts to frame and reinstall in new position.

Note: Once holes have been drilled, both positions are interchangeable.

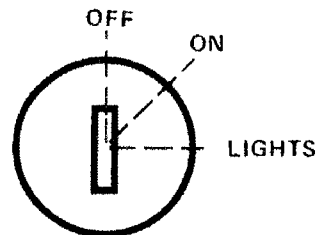
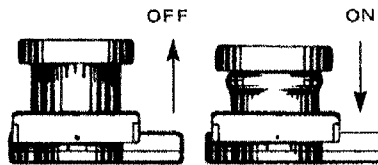
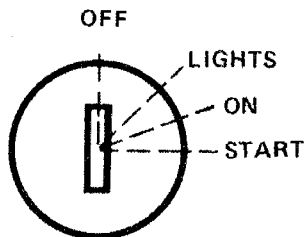

STARTING PROCEDURE

Warning: Never run the engine at high RPM when the tracks of the vehicle are raised off the ground.

Note: Before starting the engine make sure the kill button is in the released up-position.

Electric Starting:

1. Insert key in ignition switch.
2. Engage choke. (Choke is not necessary if engine is warmed up).
3. Test throttle operation then apply throttle lever slightly.
4. Turn ignition key clockwise until starter engages.

Caution: Do not engage starter longer than 30 seconds. If engine does not start on first try, key must be turned fully back to OFF each time. Allow starter to cool for 2 minutes before repeating procedure.

5. **Release** throttle and key **immedi-**

ately engine has started. Disengage choke.

6. Allow the engine to warm up before operating at full throttle.

Caution: Never operate the Ski-Doo snowmobile with the battery removed or disconnected.

Manual Starting

1. Insert key in ignition and turn to ON position.
2. Engage choke. (Choke is not necessary if engine is warmed up).
3. Test throttle operation then apply throttle lever slightly.
4. Grasp manual starter handle firmly and pull slowly until a resistance is felt then pull vigorously and engine will start. Allow handle to return slowly to its original position. If engine does not start, repeat the procedure.

Note: Do not pull starting rope to its fullest extent or allow starting handle to "fly back" to its original position.

5. **Release** throttle and disengage choke **immediately** engine has started.
6. Allow the engine to warm up before operating at full throttle.

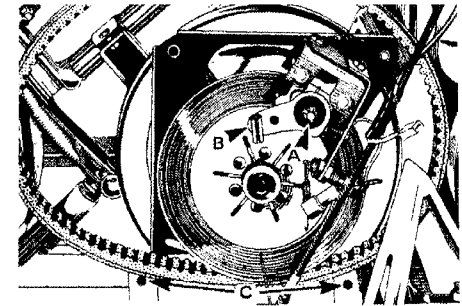
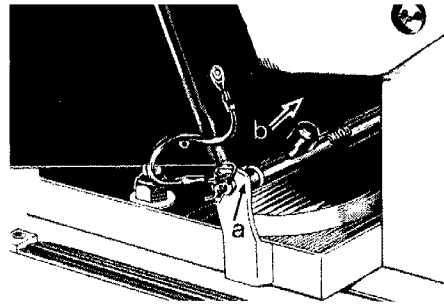
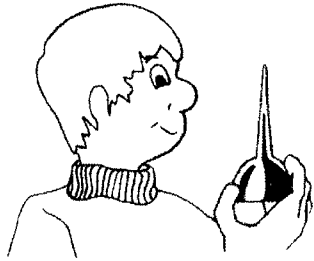

LUBRICATION

Code	Weekly	Page
W1	Steering Mechanism	11
W2	Gear Box Oil Level	11
W3	Suspension	11
Code	Bi-Monthly (20 hours)	Page
BM1	Drive Pulley	12
Code	Monthly (40 hours)	Page
M1	Driven Pulley	12

Above items in the lubrication chart will be serviced during all dealer inspections.

Cab Removal

Unlock latches (2), disconnect junction block at right side of engine, remove fuel tank cap and lift cab.

Warning: It can be dangerous to run engine with cab off.

Pulley Guard Removal

1. Remove cab.
2. Pull out retaining clip and push on spring bolt to disengage pin from bracket.
3. Move pulley guard toward front of vehicle to disengage it from bracket.

Warning: Engine should be running only when pulley guard is secured in place.

Drive Belt Removal

1. Remove cab and pulley guard.
2. Remove hair cotter pin and slacken brake adjusting screw (A). Disengage brake housing from lower brake lever (B).
3. Remove the two (2) bolts holding lower disc brake bracket to the frame (C). Disconnect light switch connector. Pivot the brake bracket assembly half a turn.
4. Open the driven pulley. Twist and

push the sliding half then **hold** in open position.

5. Slip the belt out from the drive pulley and remove from vehicle by passing it under the driven pulley and disc brake assembly.

6. To install drive belt follow reverse procedure. Check brake adjustment.

Warning: Never run the engine without drive belt installed. Running an unloaded engine can prove to be dangerous.

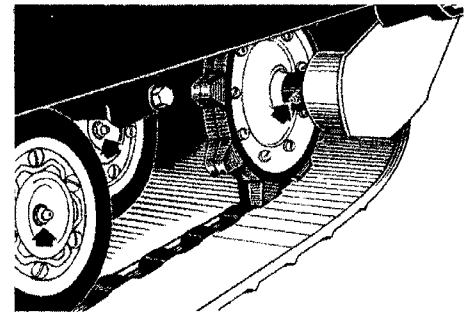
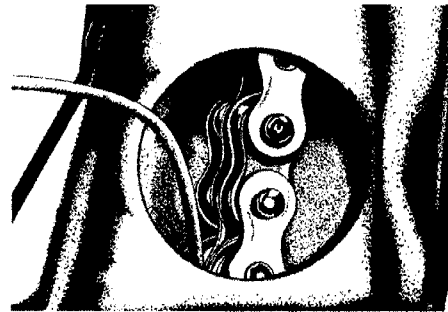
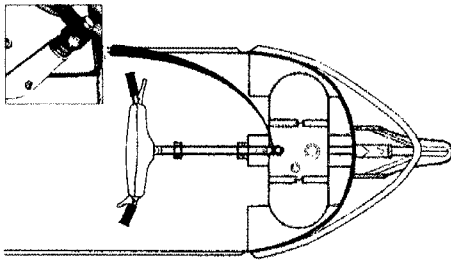

(W1) Steering Mechanism

Using light machine oil, lubricate the spring located on top of steering column housing. Allow oil to run in. Oil the mobile contact point at bottom end of steering arm. Using a small brush, dipped in low temp grease, lubricate steering arm ball joint. Grease the ski leg at grease fitting until new grease appears at the joint. Lubricate spring coupler bolt with oil.

(W2) Gear Box Oil Level

All 440R and 440ER models have an oil capacity of 12 ozs. The 640ER model has an oil capacity of 16 ozs. To check level:

1. Remove rubber inspection cover located on bottom right side of gear box.
2. Using a rigid piece of wire as dipstick, check oil level. On 440R and 440ER models, oil level must reach 2¼" on dipstick. On 640ER model, oil level must reach 3¼". To fill, remove filler cap (red cap), from top of gear box. Refill as required using Ski-Doo® chain case oil.

(W3) Suspension

Grease the suspension bogie wheels with low-temp grease, using a low pressure grease gun. Pump through the grease fitting at the centre of each wheel until new grease appears at the joint of inner side of shaft. To grease the inner side bogie wheels tilt vehicle on its side and apply pressure on track to expose grease fittings. Also grease rear axles at grease fittings.

*Trademark Bombardier Limited

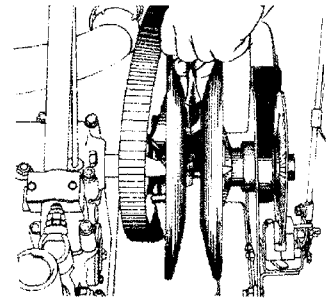
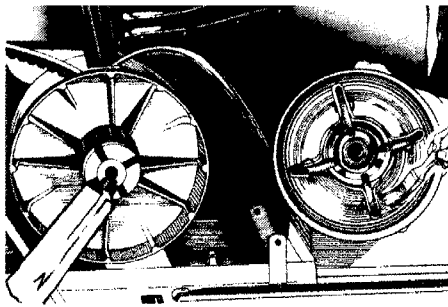
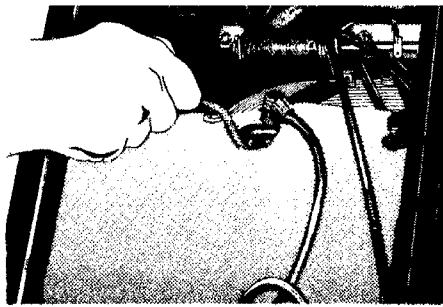

(BM1) Drive Pulley

Note: The drive pulley of the Alpine 640ER model is self-lubricating and requires manual lubrication only at storage.

1. Remove cab and pulley guard then slip off drive belt.
2. Remove centrifugal governor as follows:

- Remove spark plugs and position the left side (P.T.O.) piston $\frac{3}{4}$ " to $1\frac{1}{4}$ " **before** top dead center, making sure that the piston closes the exhaust port.
- Accede by the spark plug hole and pack the cylinder with $\frac{3}{16}$ " dia. rope.
- Pull manual starter to rotate crankshaft until piston bears against "cushioning".
- Unscrew centrifugal bolt, remove centrifugal governor, outer half and spring then pull rope from spark

plug hole.

3. Thoroughly clean the inner pulley shaft using fine steel wool and a clean cloth.
4. Apply a light coat of low-temp grease to the four (4) flyweights of the centrifugal governor.
5. Install spring and outer half. Making sure that the aligning mark on inner pulley half coincides with the aligning mark of the outer pulley half, pack inside of pulley shaft with low-temp. grease.
6. Using light machine oil, lubricate the governor bolt threads and install governor. Torque bolt to 33-40 ft/lbs.

Note: Installation procedure is reversed insuring that the rope is inserted into same cylinder when piston is $\frac{3}{4}$ " approx. **after** top dead center.

Warning: Make sure that the governor bolt is fully tightened before removing rope from cylinder.

(M1) Driven Pulley

With cab removed, grease the driven pulley shaft as follows:

1. Remove pulley guard and slip off drive belt. Open the driven pulley (push and twist sliding half).
2. Thoroughly clean the driven pulley shaft.
3. Apply a light coat of low-temp grease on the shaft. Always lubricate lightly and wipe off surplus.

Note: Activate the sliding half several times to distribute lubricant over full length of shaft. Be careful that lubricant does not get on inner halves of pulley.

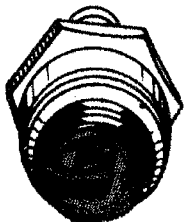

Carbonized

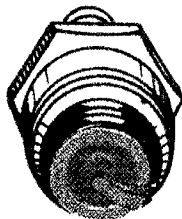

Normal

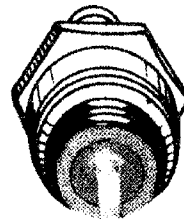

Burnt

MAINTENANCE

Code	Weekly	Page
W1	Spark Plugs	13
W2†	Battery	14
W3	Suspension Springs	14
W4	Tracks	14
W5	Track Tension & Alignment	14
W6	Carburetor Adjustment	15
W7	Drive Belt Condition	16
W8	Drive Chain Tension	16
Code	Monthly	Page
M1	Carburetor Flange Nuts	16
M2	Brake	16
M3	Steering Adjustment	16
M4	Engine Head Nuts	16
M5	Engine Mount Nuts	17
M6	Vehicle General Inspection	17

†(Electric Model only)

Above items will be serviced during all dealer inspections.

(W1) Spark Plugs.

1. Open access door. Disconnect spark plug wires and remove plugs.
2. Check condition of plugs.
 - A brownish tip reflects ideal conditions, (proper carburetor adjustment, spark plug heat range, etc.)
 - A black insulator tip indicates fouling caused by; carburetor idle speed mixture too rich, incorrect fuel mixing ratio, wrong type of spark plug (heat range), or excessive idling.
 - A light grey insulator tip indicates a lean mixture caused by; carburetor idle speed mixture adjusted too lean, wrong spark plug heat range, incorrect fuel mixing ratio, or a leaking seal or gasket.

Caution: Having a spark plug with too hot a heat range will cause serious engine damage if the severity of engine operating conditions are greater than the plugs' intended range.

3. Check spark plug gap using a wire feeler gauge. Gap must be .020"
4. Reinstall plugs and connect wires.

Caution: If when checking spark plug color, you find that the engine is not running under ideal conditions, contact your authorized Ski-Doo dealer.

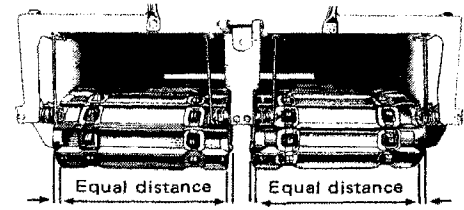
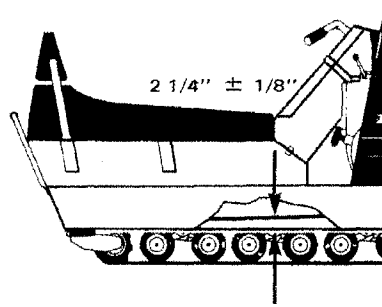

(W2) Battery

Remove battery caps then check electrolyte level at each cell. Electrolyte level must touch bottom of filler hole. If necessary, add distilled water.

(W3) Suspension Springs

With engine **off**, visually inspect suspension springs. Replace any weak or broken spring.

(W4) Tracks

Lift rear of vehicle and support it off the ground. Place gear shift lever in forward position. With engine **off**, rotate tracks by hand and inspect condition. If bad cuts or missing track inserts are noted, see your dealer.

Note: Without these inserts continual abrasion would wear and cut the track therefore, always replace a missing or damaged insert as soon as possible.

(W5) Track Tension and Alignment

Lift the rear of vehicle and support it off the ground. Using a rule, check track tension. On Valmont models, take measure at the middle set of bogie wheels. On Alpine model, check measure at the second set of bogie wheels from rear. The tension of each track should be $2\frac{1}{4}'' \pm \frac{1}{8}''$ between top inside edge of track and bottom of footboard.

To adjust track use the following procedure:

1. Loosen link plate spring lock nuts (4) located on inner side of link plate springs.
2. Turn outer side adjuster bolt(s) clockwise to tighten track(s), counter-clockwise to slacken.
3. Start engine and allow tracks to rotate **slowly**. Check if tracks are well centered and turn evenly on the rear

sprockets. The distance between track edges and link plates should be equal.

To correct:

1. Turn inner side adjuster bolt(s) counter-clockwise to bring track closer to center link plate(s), turn clockwise to withdraw track(s) from link plate(s).
2. Tighten link plate spring lock nuts.
3. Rotate tracks slowly and recheck alignment.

Warning: Before checking track alignment, ensure that the track is free of all particles which could be thrown out while track is rotating. Keep hands, feet and clothing clear of track.

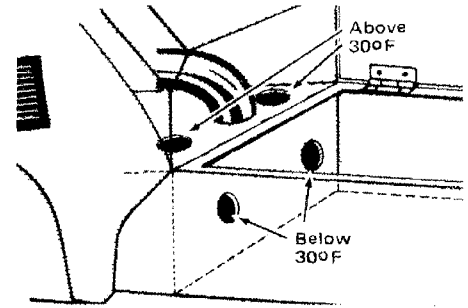
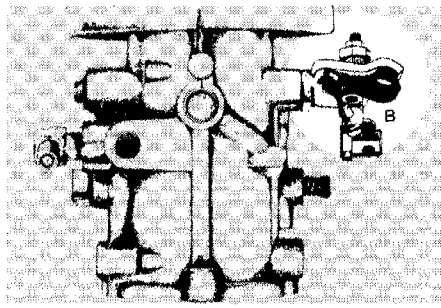
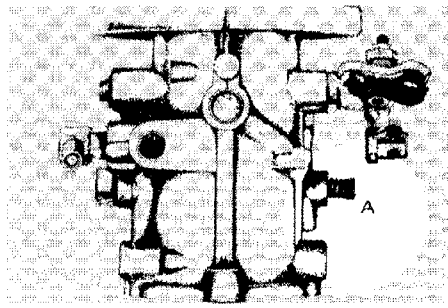

(W6) Carburetor Adjustment Maximum Throttle Opening

With engine **off**, unscrew the Idle Speed Adjusting Screw until a gap exists between screw end and carburetor shaft lever. Depress the throttle lever at handlebar and hold. Throttle butterfly should be horizontal when the lever gently touches the handlebar grip. To adjust for maximum opening, loosen screw at point where cable joins carburetor lever.

With finger, hold carburetor throttle lever in fully open position (up), pull cable downward until taut. Retighten screw.

Warning: Before starting engine, carburetor throttle lever must return to idle position by contacting with the tip of Idle Speed Adjusting Screw. Never start engine unless this situation is verified.

Idle Mixture Adjustment (A)

A primary adjustment (with engine **off**) should be made by first turning Idle Mixture Screw fully clockwise until closed. Back off screw $\frac{3}{4}$ of a turn counter-clockwise.

Note: Do not close too tightly as needle and/or seat can be damaged.

For final adjustment, start engine and allow it to warm up. Turn Idle Mixture Screw until engine reaches maximum R.P.M. and obtain a steady idle and a fast response of the engine to the throttle.

Idle Speed Adjustment (B)

Turn the Idle Speed Adjusting Screw clockwise to increase idling speed, counter-clockwise to decrease.

Air Silencer Box

Located in the front section of the storage compartment. When operating the vehicle in temperatures exceeding 30°F , the two (2) rubber plugs must block the engine side orifices to allow cold air circulation. In temperatures below 30°F the plugs must be repositioned to block the seat side orifices. This will trap the warm air being emitted from the engine and direct it to the carburetor. Plug seating determines circulating air temperatures.

Caution: Observe temperature changes and locate plugs accordingly. Incorrect location of plugs may cause carburetor ice-up or engine overheating. Clothing, placed in underseat compartment, can restrict the plug/seat air flow.

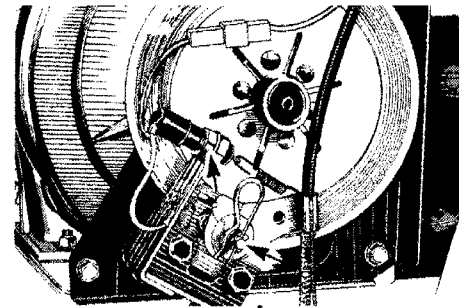
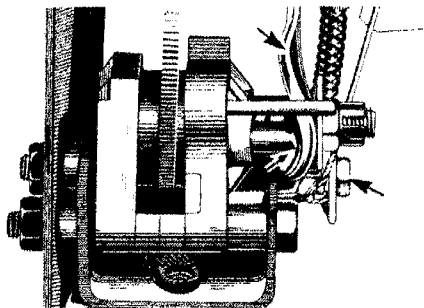
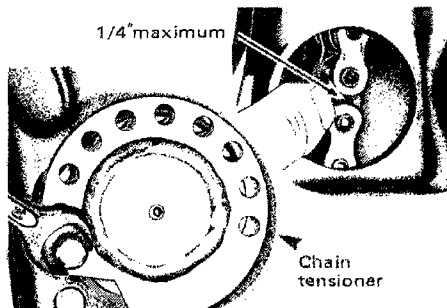

(W7) Drive Belt Condition

With engine **off**, inspect drive belt. If belt is less than $\frac{7}{8}$ " wide or if it shows abnormal or uneven wear it should be replaced.

Note: Probable cause of abnormal wear is pulley misalignment. Contact your dealer.

(W8) Drive Chain Tension

Run vehicle forward so that true free-play can be taken. Check tension then turn driven pulley $\frac{1}{2}$ turn counter-clockwise and recheck. Starting from maximum reading, adjust chain tension to $\frac{1}{4}$ " free-play.

1. Remove capscrew locking chain tensioner in place. (Tensioner is located at bottom left of gear box).
2. Rotate the tensioner as required to obtain correct chain tension.
3. Replace capscrew to lock chain tensioner in place.

(M1) Carburetor Flange Nuts

After the first 2 hours of operation, check tightness of carburetor flange nuts. Open tab locks, tighten nuts and close tab locks.

Caution: Tab locks must be replaced after opening them three times.

(M2) Brake

Brake should be fully applied when lever is 1" from handlebar. To adjust:

1. With cab removed, slacken cable lock nut located at cable end nearest frame. Manoeuvre the lower brake lever and brake cable until the pin pushers are seated directly in the "cam" of brake lever. Lock cable in position.
2. Tighten the caliper nut until a disc/puck friction is felt. Back off nut slightly.
3. Check operation of brake.

Note: Always check the stop light to see if it functions after performing brake

adjustment. To adjust, loosen stop-light switch lock nuts and adjust to proper length.

(M3) Steering Adjustment

Ski should be perpendicular to handlebar. To align:

1. Remove bolt securing handlebar to steering column.
2. Remove handlebar to expose splined end of steering column.
3. Reposition handlebar on splines so that it is perpendicular with ski. Install and fully tighten bolt.

(M4) Engine Head Nuts

With cab removed, check that engine head nuts are tight and equally torqued. (16 to 18 ft/lbs when **cold**).

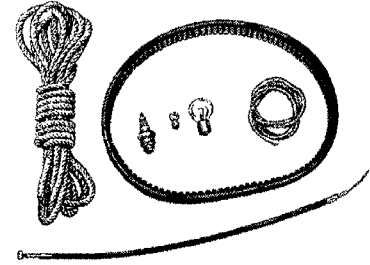
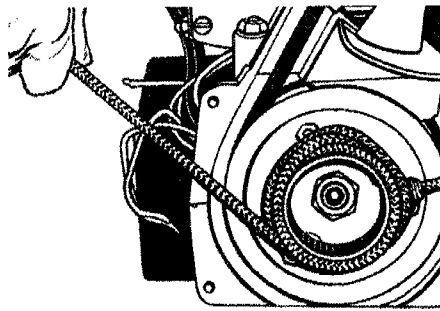

EMERGENCY GUIDE

(M5) Engine Mount Nuts

With cab and console removed, check engine mount nuts. Retighten if necessary.

(M6) Vehicle General Inspection

With cab removed, check electrical wiring and components, retighten loose connections. Check for stripped wires or damaged insulation. Repair or replace as necessary. Thoroughly inspect the vehicle and tighten loose bolts, nuts and linkage. Install cab and clean the chassis.

Burnt Light Bulb

If headlamp is burnt, stop engine and remove cab. Unfasten bulb retainer clips. Detach bulb and replace. If taillight is burnt, expose bulb by removing red plastic lens. To remove, unscrew the two (2) Phillips head screws.

Broken Throttle Cable

Remove throttle cable and replace. Check lever operation. If necessary replace housing. **Do not** start the engine until levers return swiftly.

Broken Rewind Starter Rope

Abuse of the rewind starter may cause the rope to fray and break. Should this situation arise, remove starter unit using 10 mm wrench supplied in tool kit. Transfer rope grip to your emergency rope. Place starter unit in seat compartment. Make a knot at the end of emergency starter rope and wind rope

around starter pulley. Pull vigorously as per usual manual start. See your dealer for immediate repair of starter unit.

Emergency Materials

In addition to those tools which the manufacturer provides, you should also carry the following:

Tools: General Purpose Pliers—Adjustable Wrench ($\frac{3}{4}$ " opening)—Flashlight.

Spare Parts: Spark Plug—Drive belt—Headlamp and Taillight bulbs—Throttle Cable and Housing—Starting and towing rope—Fuse (electric models).

Important: Always carry spare plugs and drive belt.

TROUBLE SHOOTING GUIDE

Symptoms	Possible Causes	What To Do
Engine turns over but fails to start or starts with difficulty	1. No fuel to the engine	Check the tank level and fill up with correct gas-oil mixture. Check for possible clogging of fuel line, item 5.
	2. Spark plug	Check for fouled or defective spark plug. Disconnect spark plug wire, unscrew plug and remove from cylinder head. Reconnect wire and ground exposed plug on engine head, being careful to hold away from spark plug hole. Follow engine starting procedure and check for spark. If no sparks appear, replace spark plug. If trouble persists, check item 3.
	3. Faulty ignition	Disconnect spark plug wire from plug, unscrew the spark plug cap then hold wire about 1/8" from the cylinder head. Follow engine starting procedure and if no sparks appear, it means a faulty ignition system. Do not attempt to repair. Contact your dealer.
	4. Flooded engine	Disengage choke, wait 60 seconds or more then depress throttle lever fully and try to start engine. Release throttle lever immediately after engine starts.
	5. Clogged fuel line (water or dirt)	Remove and clean the fuel filter. Change filter cartridge if necessary. Check condition and connections of fuel lines. Check the cleanliness of the fuel tank. Clean tank if necessary. (See Fuel Tank, Storage Section).
	6. Faulty Carburetor	First make primary adjustments on carburetor (See Maintenance Section). If carburetor is still faulty, contact your dealer for repair.
	7. Too much oil in fuel	Drain the fuel tank and refill with the correct gas/oil mixture.
	8. Breaker points	Breaker points may be worn or out of adjustment. Contact your dealer.
	9. Poor engine compression	Running with a lean fuel mixture may produce excessive engine wear resulting in poor engine compression. If this occurs, contact your dealer at once.
Engine will not turn manually	1. Seized engine	In the case of a seized engine, contact your dealer. Seizure is a direct result of poor lubrication.

Symptoms	Possible Causes	What To Do
Engine will not start (electric model only) Note: If failure is in starting system, engine will start manually	1. Poor connections or Burnt Fuse	Check for loose or corroded battery and starter connections. Tighten and clean, also check fuse located on red wire located under seat compartment. Try to restart engine electrically. If engine still does not start, check item 2.
	2. Battery	Check condition of battery by turning lights ON. If lights are dim or out, battery may be discharged or defective. Contact your dealer to charge or replace.
	3. Starter	If wire connections are tight and fuse and battery are all in working order, most probable cause of trouble is defective starter. Contact your dealer for repair.
Engine lacks acceleration or power	1. Fouled or defective spark plug	Check item 2 of "Engine turns over but fails to start or starts with difficulty".
	2. Clogged fuel line (water or dirt)	Check fuel line condition. (See item 5 of "Engine turns over but fails to start or starts with difficulty").
	3. Carburetor	Readjust the carburetor. (See Maintenance Section). If trouble persists, contact your dealer.
	4. Defective ignition	First check item 2 and 3 of "Engine turns over but fails to start or starts with difficulty". If the ignition system still seems defective, contact your dealer.
	5. Engine	If unable to locate specific symptoms, contact your dealer.
Engine continually backfires	1. Faulty spark plug	Check item 2 of "Engine turns over but fails to start or starts with difficulty".
	2. Overheated	Contact your dealer.
	3. Engine timing incorrectly set	Contact your dealer.
Snowmobile cannot reach full speed	1. Drive belt	Check for defective or worn drive belt. Replace if necessary.
	2. Incorrect track adjustment	Check track tension and alignment. Readjust to specifications. (See Maintenance Section).
	3. Faulty engine	Check items 1 to 5 of "Engine lacks acceleration or power"
	4. Pulley misaligned	Contact your dealer.

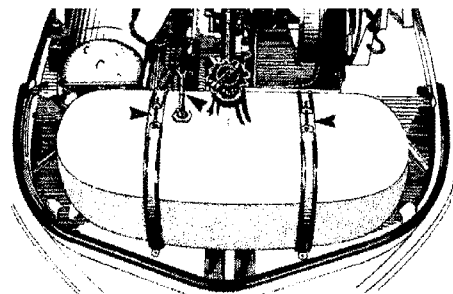
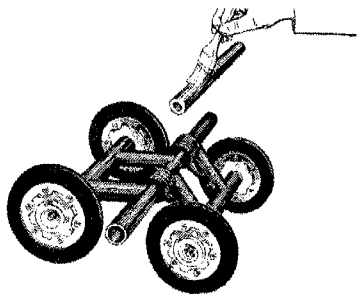
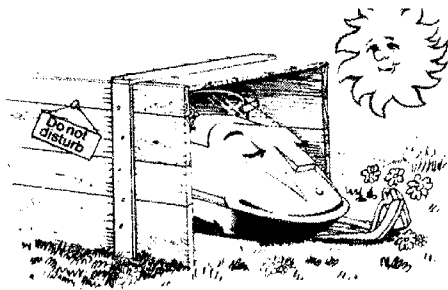

OFF-SEASON STORAGE

It is during Summer, or when a vehicle is not in use for a month or more, that proper storage is a **necessity**. If you lack the time or proper tools, be sure to see your authorized Ski-Doo dealer.

(S1) Tracks

1. Inspect tracks for cuts, missing track inserts or broken rods and make any necessary replacement.
2. Lift rear of vehicle until tracks are clear of ground then support with brace or trestle. The Ski-Doo snowmobile should be stored in such a way that the tracks do not stay in contact with cement floor or bare ground.

Note: The tracks should be rotated periodically, (every 40 days).

(S2) Suspension

1. Remove the bogie wheel sets from the vehicle.
2. Remove cross shaft from bogie wheel set. Clean bogie wheel assembly

and cross shaft of dirt or rust.

3. Grease each bogie wheel until all old grease is flushed out.
4. Spray bogie wheel springs with Ski-Doo* metal protector. If unavailable, wipe with cloth or rag soaked in oil. Check condition of shaft and replace if bent or worn. Apply a coat of low temp. grease on cross shaft.
5. Reassemble entire bogie wheel set, making sure assembly moves freely.
6. Reinstall bogie wheel set.
7. Repeat above steps on remaining bogie wheel sets.
8. Lubricate rear hubs through grease fittings.

(S3) Ski Assembly

1. Wash or brush all dirt or rust accumulation from ski and spring.
2. Grease ski leg at grease fitting.
3. Check condition of ski runner. Replace if worn.

4. Apply Ski-Doo* metal protector on ski assembly. If unavailable, wipe the entire ski with a cloth soaked in oil to prevent rust formation.

(S4) Fuel Tank

1. Disconnect fuel lines by pulling plastic lines away from tank.
2. Remove tank retainer strap bolts, pull out fuel tank retainer straps. Lift fuel tank from vehicle and drain it.
3. Rinse inside of tank thoroughly with fresh gasoline.
4. Reinstall fuel tank.

Warning: Gasoline is flammable and explosive under certain conditions. Always perform this procedure in a well ventilated area. Do not smoke or allow open flames or sparks in the vicinity.

*Trademark Bombardier Limited

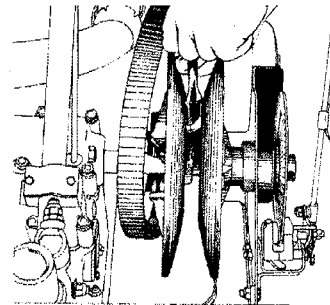
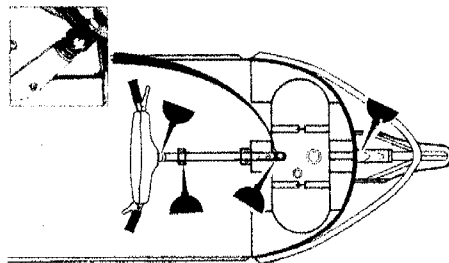
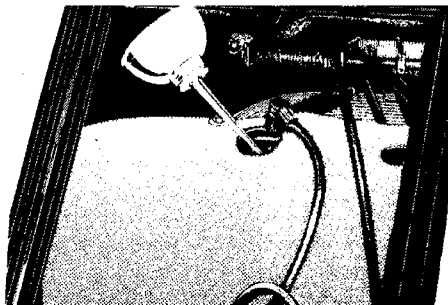

(S5) Carburetor

The carburetor must be dried out completely to prevent gum formation during the storage period.

1. Assure that fuel lines are disconnected then start the engine and run it out of gas.

2. Engage choke then pack the carburetor throat with a clean piece of cloth and turn the engine a few more times. The suction should eliminate the remaining fuel.

(S6) Cylinder Lubrication

1. Remove spark plug.

2. Operate rewind starter to bring piston at **top** position.

3. Pour about one spoonful of Ski-Doo* oil into spark plug hole.

4. Slowly crank engine 10 to 12 times using manual starter.

Caution: To prevent magneto damage, make sure that the ignition switch is at

the OFF position.

5. Repeat above steps for other cylinder. Install spark plug.

Note: This operation should be repeated every 40 days during storage.

(S7) Gear Box

Drain gear box and refill with 12 ozs. (440R and 440ER models), or 16 ozs. (640ER model), of fresh Ski-Doo* chain case oil.

(S8) Controls

1. Oil steering mechanism linkage.

2. Oil moving joints of brake mechanism. **Avoid getting oil on brake pucks.**

3. Coat all electrical connections and switches with Ski-Doo* metal protector (greaseless).

(S9) Pulleys

1. Remove cab and drive belt.

2. Thoroughly clean the driven pulley shaft. Apply a light coat of low-temp.

grease on shaft.

3. Activate the sliding half several times to distribute lubricant.

4. Lubricate drive pulley following the procedure detailed in the Lubrication Section.

5. Spray internal pulley surfaces with Ski-Doo* metal protector.

Note: Leave drive belt **off** during entire storage period.

(S10) Battery

1. Open seat, disconnect battery and remove it from vehicle.

2. Clean outside surfaces of battery. **Do not** allow cleaning solution to enter battery.

3. Fully charge battery (trickle charge) and store in a cool, dry place.

Note: Recharge battery at least every 40 days to prevent sulphation.

*Trademark Bombardier Limited

SPECIFICATIONS

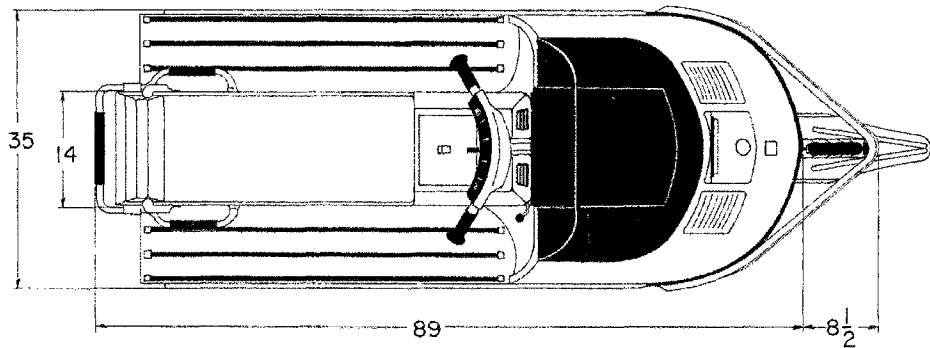
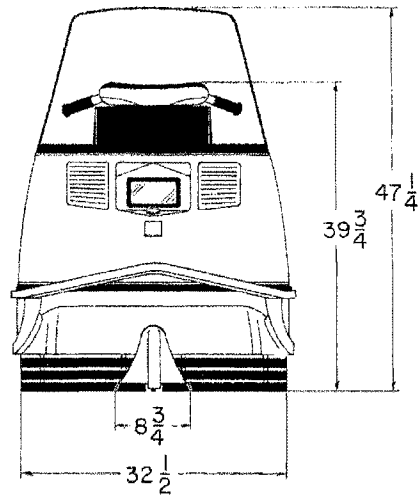
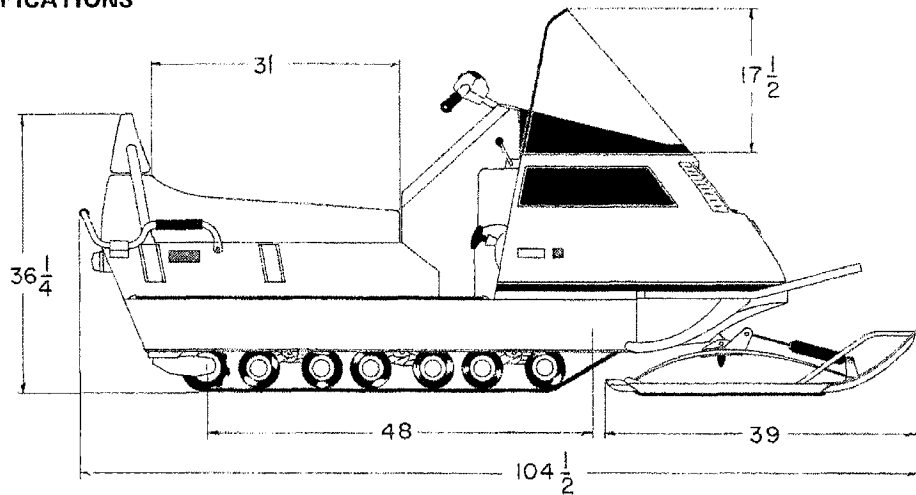

SPECIFICATIONS

MODEL	VALMONT/ALPINE	440R Valmont	440ER Valmont	440R Alpine	440ER Alpine	640ER Alpine
Engine	No. of Cylinders	Two	Two	Two	Two	Two
	Bore	67.5mm	67.5mm	67.5mm	67.5mm	76mm
	Stroke	61mm	61mm	61mm	61mm	70mm
	Displacement	436.6cc	436.6cc	436.6cc	436.6cc	635.1cc
	Compression Ratio	10:1	10:1	10:1	10:1	9:1
	Carburetor (Tillotson)	HD	HD	HD	HD	HD
	Starting	Manual	Electric	Manual	Electric	Electric
	Horse Power	30	30	30	30	N/A
Chassis	Overall Length	103 1/2"	103 1/2"	113 1/2"	113 1/2"	113 1/2"
	Overall Width	35 1/2"	35 1/2"	35 1/2"	35 1/2"	35 1/2"
	Height w/o windshield	40"	40"	40"	40"	40"
	Weight (lbs)	506	540	548	584	610
	Bearing Area	1756	1756	2160	2160	2160
	Ground Pressure (p.s.i.)	.294	.308	.254	.270	.282
Power train	Track Width	2 X 15"	2 X 15"	2 X 15"	2 X 15"	2 X 15"
	Std. Gear Ratio	17/46	17/46	17/46	17/46	17/38
Electrical System	Brake Light Coil Output	23 Watts	23 Watts	23 Watts	23 Watts	
	Lighting Coil Output	75 Watts	75 Watts	75 Watts	75 Watts	120 Watts
	Headlamp (Watt)	60/60	35/35	60/60	35/35	60/60
	Tail/Stop Light (Watt)	8/23	8/23	8/23	8/23	8/23
	Spark Plug (Bosch)	Contact your Ski-Doo dealer				M-280-T-31
	Spark Plug Gap	.020"	.020"	.020"	.020"	.020"
	Breaker Points Gap	.014" - .018"	.014" - .018"	.014" - .018"	.014" - .018"	.014" - .018"
	Voltage Regulator	Yes	No	Yes	No	No
Fuel	Tank Capacity - Imp.	5 gals	5 gals	5 gals	5 gals	5 gals
	U.S.	6.25 gals	6.25 gals	6.25 gals	6.25 gals	6.25 gals
	Gasoline	Regular	Regular	Regular	Regular	Regular
Gas/Concentrated Oil Ratio	40:1	40:1	40:1	40:1	40:1	

1973 SKI-DOO WARRANTY

Bombardier Limited (Bombardier) as manufacturer, warrants every 1973 Ski-Doo snowmobile, Ski-Boose or Carry-Boose tow sled, SOLD AS A NEW VEHICLE, BY AN AUTHORIZED SKI-DOO DEALER, to be free from defects in material, and workmanship under normal use and service, for a period of ninety (90) days subject to the following coverage period:

1. Beginning no sooner than from the date of delivery to the first retail buyer, for a period of ninety (90) consecutive days.
2. Since snow is required for snowmobiling; all deliveries **prior to December 15th, 1972**, shall be covered under this warranty from **December 15th, 1972 to March 15th, 1973**.
3. All units delivered on or after **January 2nd, 1973**, but prior to **March 31st, 1973**, shall have a warranty carry-over into the next season, starting on **December 15th, 1973**, for the unused portion of the ninety (90) day warranty.

CONDITIONS

1. That maintenance be performed, at the owner's expense, as set down in the applicable owner's manual. Any failure which occurs as a result of inadequate maintenance† or improper use shall not be assumed by this warranty.
2. Any damages to any part of the above-mentioned vehicles and their components caused through improper use or maintenance or by any part installed which is not a genuine Ski-Doo replacement part, or not installed by an authorized Ski-Doo dealer, voids any future warranty

coverage to the affected parts.

3. This warranty does not apply to any defect which results from:
 - i) misuse or accident;
 - ii) Installation of repair parts other than genuine Bombardier replacement parts or;
 - iii) Repairs by any person other than an authorized Ski-Doo snowmobile dealer;
 - iv) Lack of preventative maintenance;
 - v) Alterations or modifications other than those approved in writing by Bombardier.
4. Proof of ownership and warranty registration must be submitted to the service dealer by means of the Ski-Doo Service Card.

† **Guidelines for proper use and maintenance are detailed in each owner's manual.**

EXCLUSIONS

- **Maintenance Items and Services** are considered non-warrantable and necessary to proper functioning of the vehicle, and without limiting the foregoing the following parts and services are excluded:
- Variable speed drive belt, fan belt, windshield, filters, ignition breaker points and condensers, spark plugs, light bulbs and protective lenses, brake linings, ski runner shoes, slider shoes on variable speed pulleys, all fasteners, labels, soft trim and appearance items, lubricants and paints, and all tune-ups or adjustments required.

SKI-DOO * SHOP MANUALS

1970-1971 Completely illustrated, with over three hundred full size pages, the content includes entire sections on Engine—Carburetor—Chassis—Suspension—Electrics—etc. Lists step by step procedures for Repairs—Servicing and much much more. Covers both 1970 and 1971 vehicles. \$8.95.

1972 Over two hundred pages of up-to-date information on Repairs and Servicing. Completely illustrated. Everything you'll ever need to know about servicing your 1972 Ski-Doo snowmobile. \$7.95.

1973 Supplement edition of the '72 Shop Manual. Includes the latest design changes and servicing techniques for '73 vehicles. \$5.00.

Reserve your copy now! Send certified cheque or money order to:

Canada

Bombardier Limited,
Technical Information Centre,
8600 Decarie Blvd.,
Montreal 307, P.Q.

U.S.A.

Bombardier East Inc.,
Railroad Street,
Lee, Massachusetts, 01238

To be completed and returned with
a money order or a certified cheque
(Postage included)

NAME _____

(BLOCK LETTERS)

STREET _____

CITY _____

STATE / PROV. _____

ZIP CODE _____

SEND ME _____

1970-71 SHOP MANUAL \$8.95

1972 SHOP MANUAL \$7.95

1973 SUPPLEMENT \$5.00
(Available December '72)

*Trademark Bombardier Limited

- Any part damaged through lack of lubrication unless it is proven to be attributable to a manufacturing defect
- Blizzard models or any of the vehicles referred to in this text which may have been used for racing or professional competition
- Any damages resulting from an accident unless such damages are proven to result from a manufacturing defect
- Any losses incurred to the vehicle owner other than the parts and labour required to repair the warrantable defect

This warranty is expressly in lieu of all other expressed or implied warranties of Bombardier, its distributors and the selling dealer, including any implied warranty of merchantability or fitness for any particular purpose. Neither Bombardier, its distributors nor the selling dealer shall be responsible, under any circumstances, for any loss or damage as a result of hidden defects, accidents, misuses or other faults.

Neither the distributor, the selling dealer nor any other person has been authorized to make any affirmation, representation or warranty other than those contained in this warranty and if made, such affirmation, representation or warranty shall not be enforceable against Bombardier or any other person.

BOMBARDIER LIMITED
FEBRUARY 2, 1972

NOTE: *In the event of change of ownership, complete the notice of transfer form below in order to qualify the new owner for balance of warranty. All such transfers should be reported to an authorized Ski-Doo dealer for modification of the Ski-Doo Service Card. In the event of a lost Service Card, contact the original selling dealer for completion of the "Request for New Service Card" form. For a \$2.00 handling charge, Bombardier will mail your new personalized Service Card to you.*

Bombardier Limited,
Valcourt, Québec, Canada. February 1972.

NOTICE OF TRANSFER

Model Vehicle Serial No.

The ownership of this vehicle is transferred
 From _____

 Signature of registered owner

To _____
 Full name of purchaser *Block letters*

Address _____
 No Street or Village

 City County
 Date

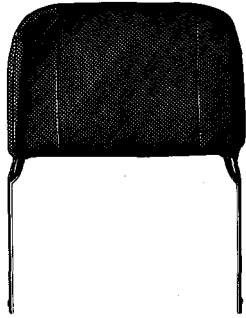

Backrest

- Easily installed on Ski-Doo* snowmobiles.
- Can be attached at two locations—center for driver only rear for passenger.
- Attractive sturdy leatherette and metal construction also available chrome coated.
- Highly recommendable for all snowmobiles carrying more than one passenger.

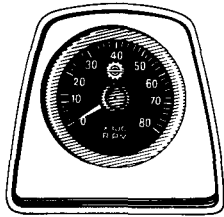

Tachometer

The tachometer registers the impulses of the magneto. Direct-reading dial indicates (in thousands) the number of revolutions per minute (R.P.M.) of the engine. Vital towards maximum performance and engine diagnosis.

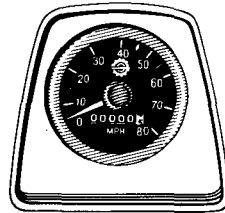

Speedometer

Linked directly to the drive axle. Direct-reading dial indicates the speed of the vehicle in miles per hour (M.P.H.). 6 digit Odometer records the number of miles travelled.

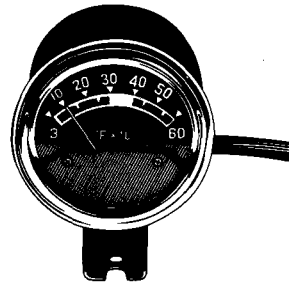

Temperature Gauge

Developed for observing changes in cylinder head temperatures. Features: high sensitivity . . . quick response . . . special heat compensating bi-metal . . . internal illumination and quick connect pick-up unit. Applicable to all models.



Snow Guard

- Prevents snow from blinding trailing snowmobiles.
- Strong thick rubber ensures long lasting durability.
- Perfectly flexible even under extreme cold.
- A must for all racing snowmobiles and an added precaution for snowmobilers on safari.
- Applicable to all models.

All genuine Ski-Doo parts and accessories are specifically designed to provide you with peak performance. Whether it's for comfort or safety, you know that you can depend on genuine Ski-Doo parts and accessories available only at Ski-Doo dealers across the country.

. . . and the Bombardier corporation is behind them all.

*Trademark Bombardier Limited

480-0056 Lith'd in Canada